

ITM. / ART. 1477872

MFR# OD201

5-Piece Dining Set

Ensemble de salle à manger de 5 pièces

Juego de comedor de 5 piezas



Assembly Instructions

Instructions d'assemblage

Instrucciones de ensamble

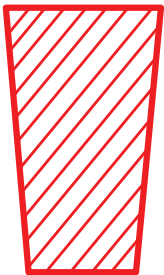

IMPORTANT, RETAIN FOR FUTURE REFERENCE: READ CAREFULLY
For more information, visit: www.northridge-home.com

IMPORTANT, À CONSERVER POUR DE FUTURS BESOINS
DE RÉFÉRENCE : À LIRE SOIGNEUSEMENT
Pour en savoir plus, visiter le www.northridge-home.com



IMPORTANTE: CONSERVE PARA FUTURA REFERENCIA. LEA
CUIDADOSAMENTE
Para más información, visite: www.northridge-home.com

For parts or customer service call: **1-866-387-8065**

Or email: info@northridge-home.com

(English, French and Spanish languages spoken)

Monday-Friday 8am - 8pm (EST).

Telephone number is only valid in the United States and Canada.

Pièces et service à la clientèle : **1-866-387-8065**

Courriel : info@northridge-home.com

(Anglais, français et espagnol)

Du lundi au vendredi : de 8 h à 20 h (HNE).

Ce numéro de téléphone n'est valide qu'aux États-Unis et au Canada.

Para solicitar piezas o hablar con un representante
de atención al cliente, llame al **1-866-387-8065**

Correo electrónico: info@northridge-home.com

(Atención en español, inglés y francés)

De lunes a viernes, de 8 a. m. a 8 p. m., hora del este.

El número es válido solamente en los Estados Unidos y Canadá.

Telefono no válido en Mexico.

WARNING: Small parts choking hazard

AVERTISSEMENT : Risque d'étouffement – Comprend de petites pièces

ADVERTENCIA: Piezas pequeñas. Riesgo de asfixia.

A x 1

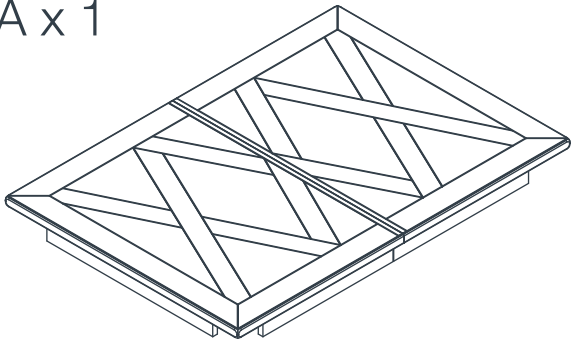

B x 4



C x 8

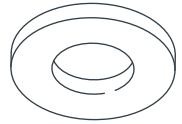

D x 8

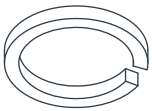

E x 8

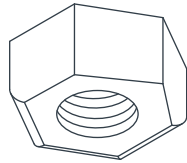

F x 1

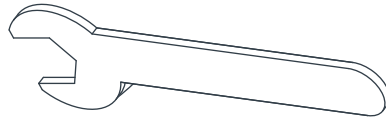

G x 1

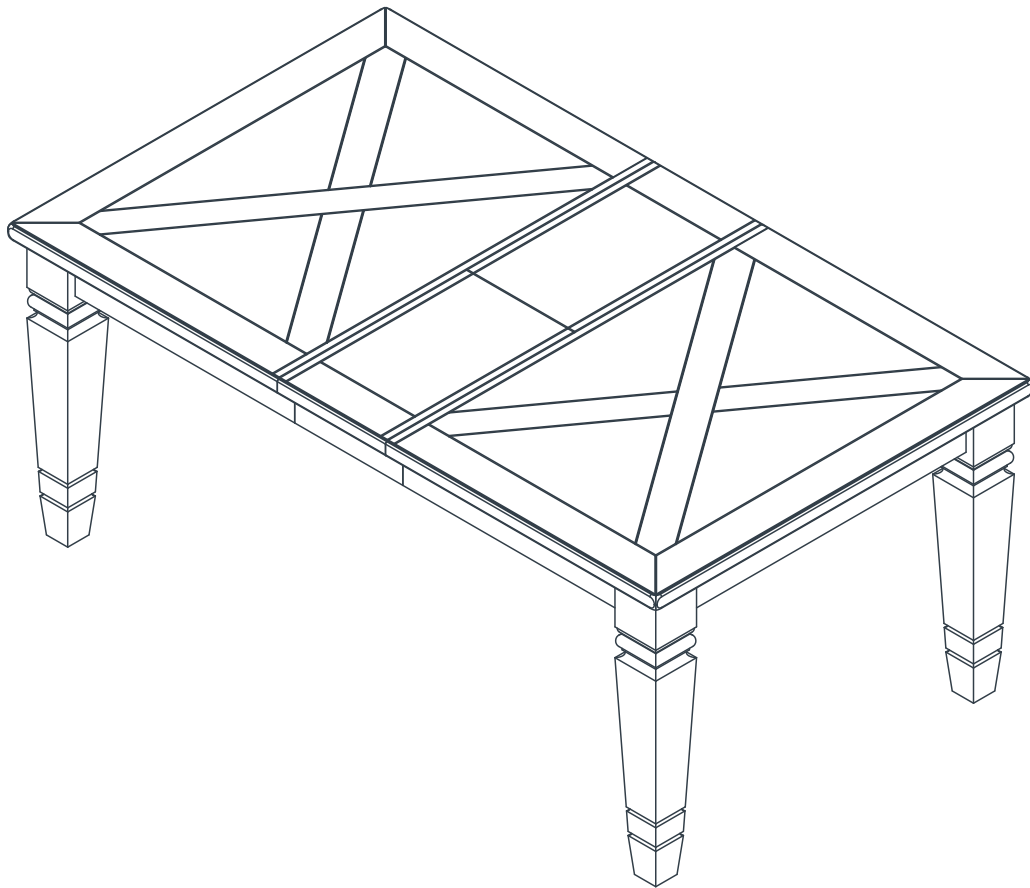
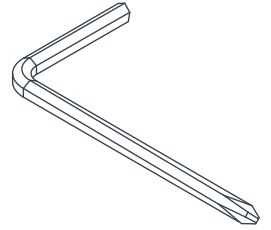

Touch-up Pen
Crayon de retouche
Pluma para retoques



1

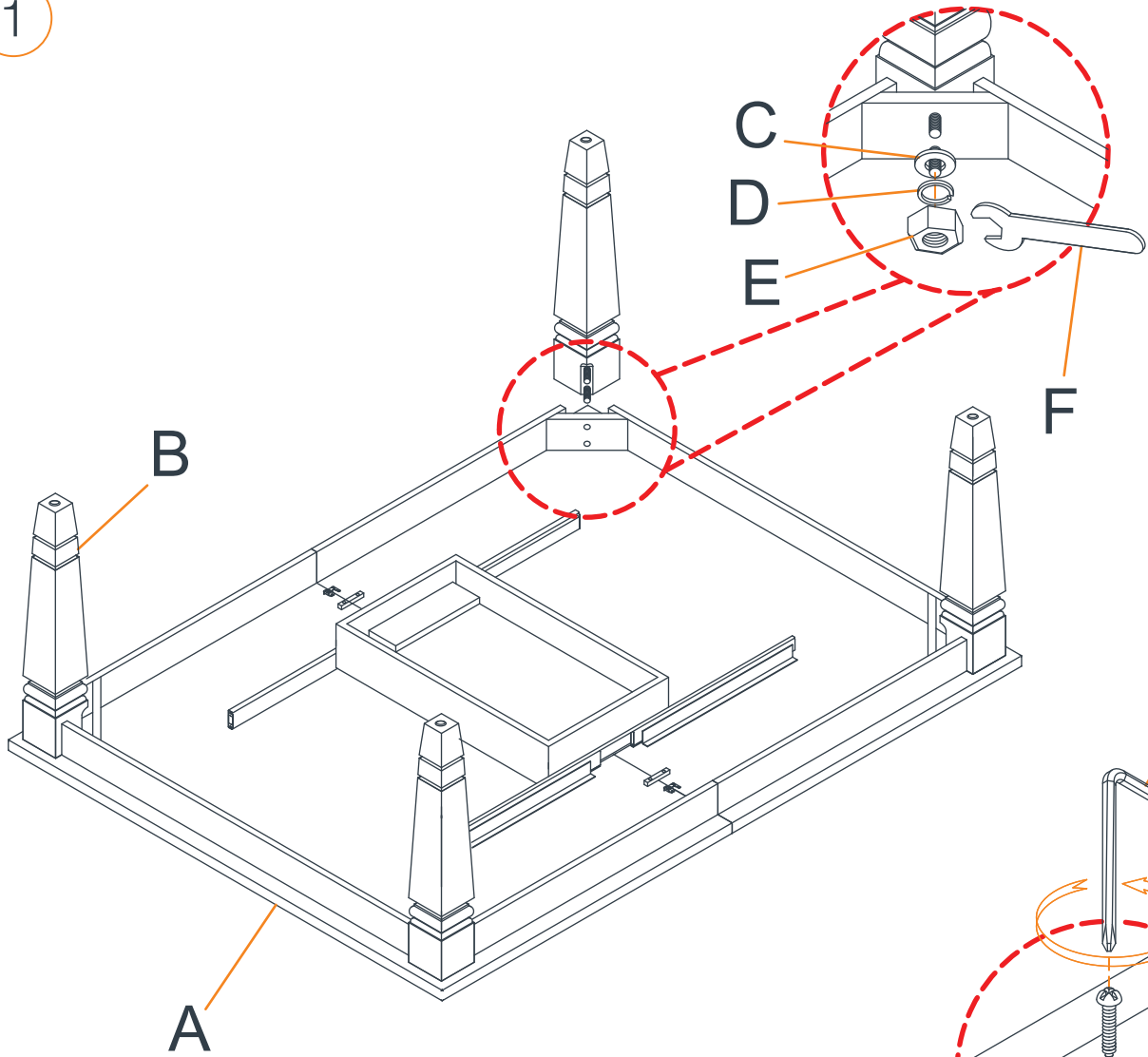

2

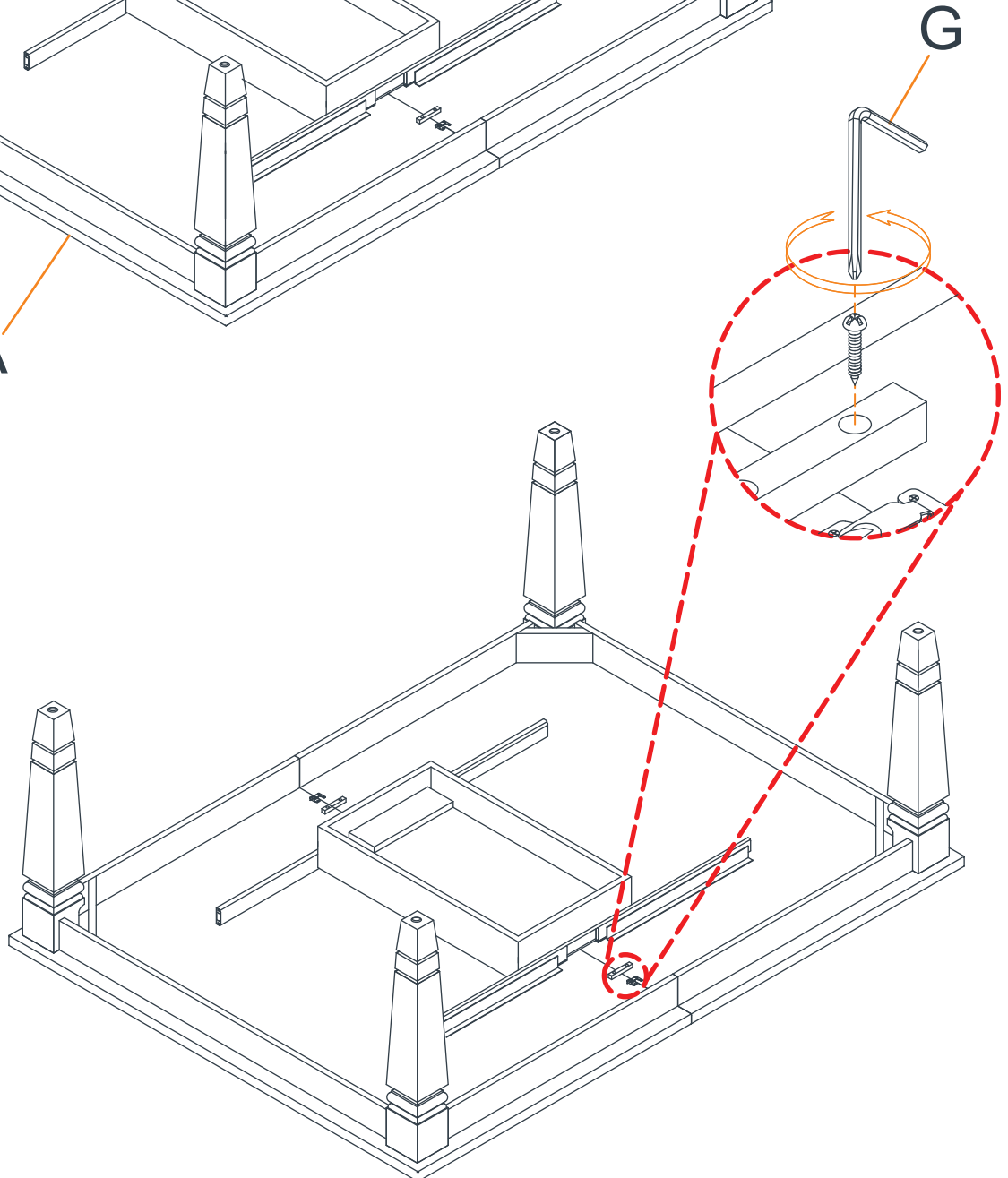

3

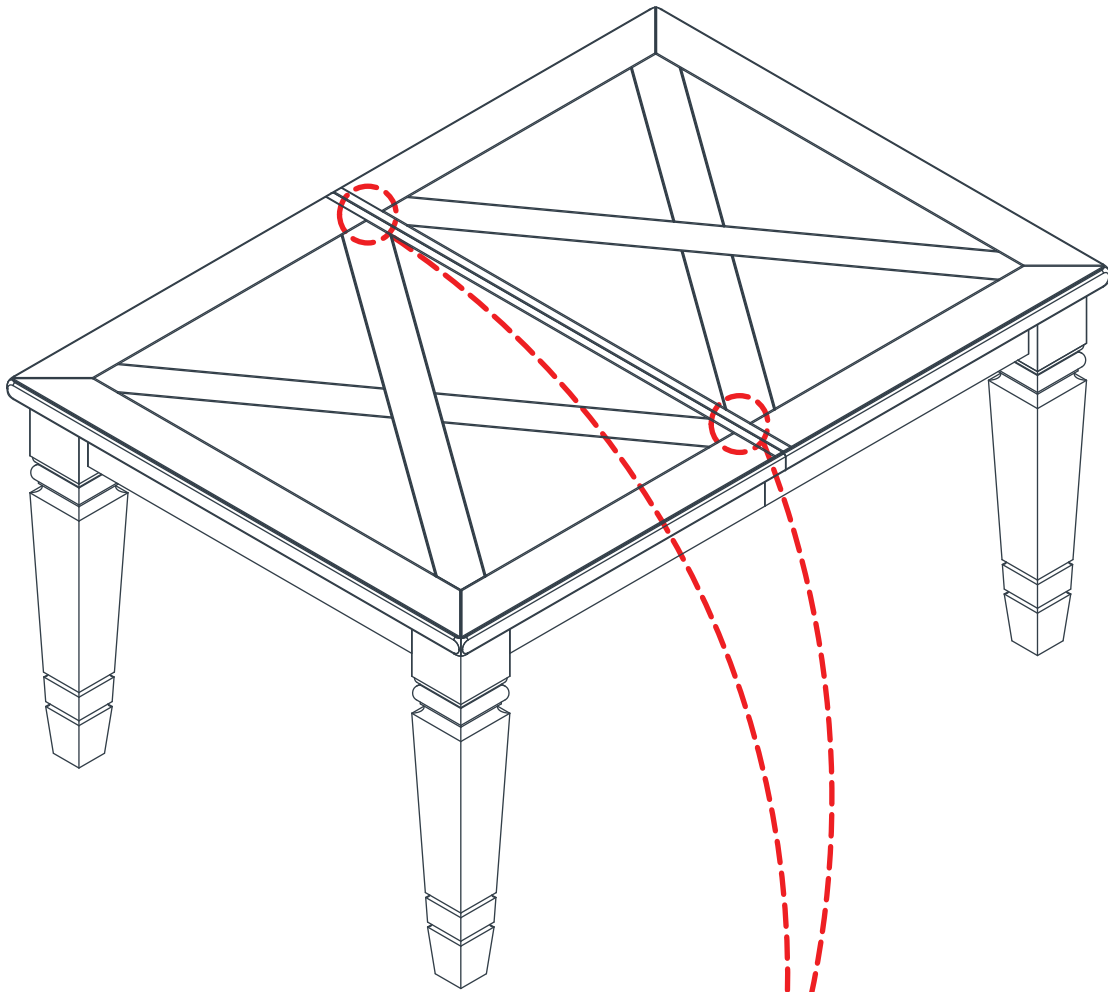

Warning: Do not move table if the leaf locks are not secured in the locked position.

Avertissement : Ne déplacez pas la table si les verrous du vantail ne sont pas sécurisés en position verrouillée.

Advertencia: No mueva la mesa si los bloqueos de las hojas no están asegurados en la posición bloqueada.

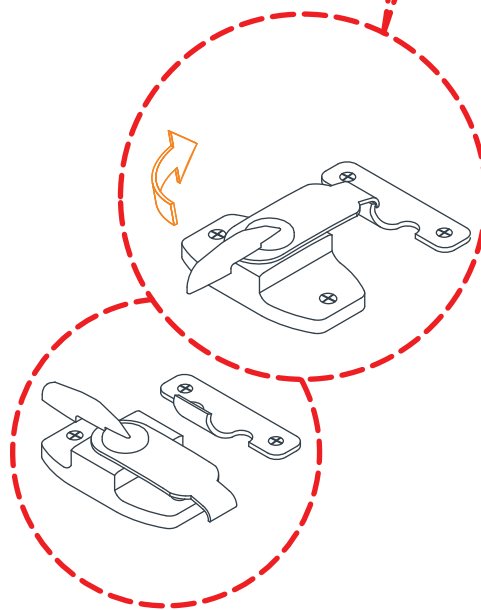

4

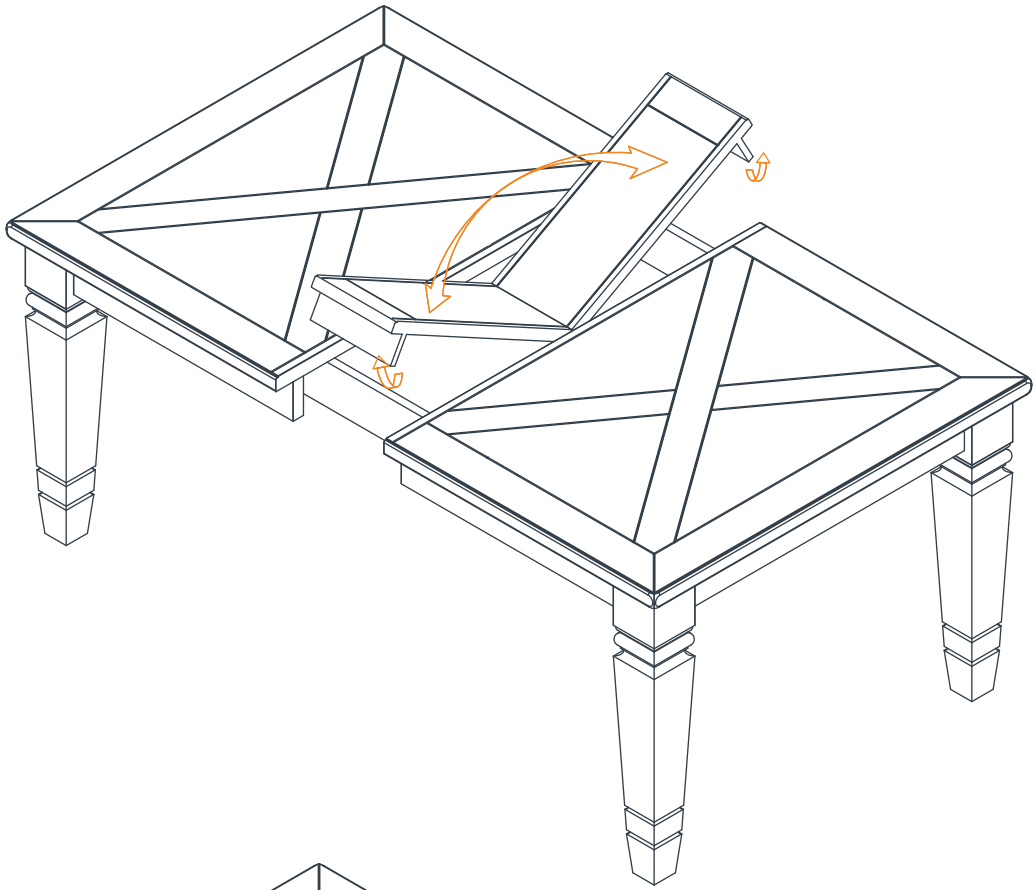

5

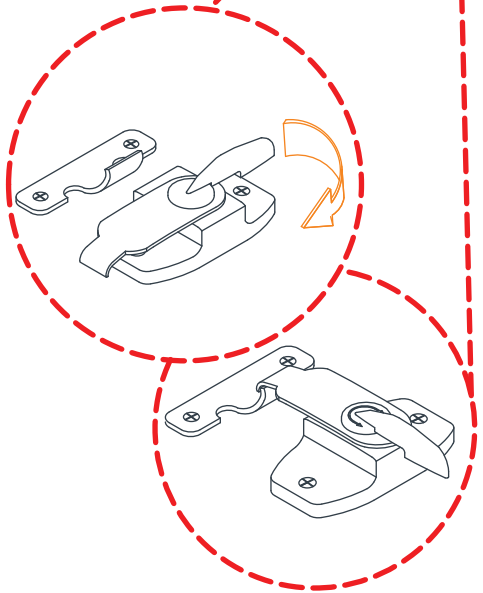
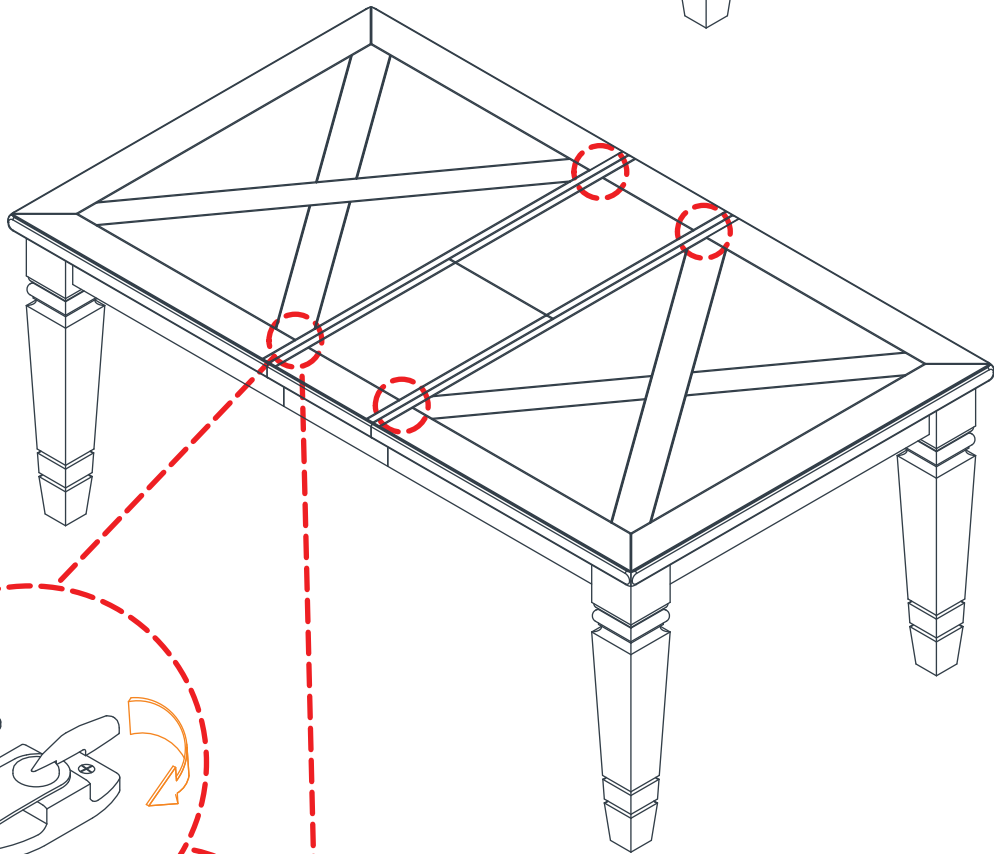

6

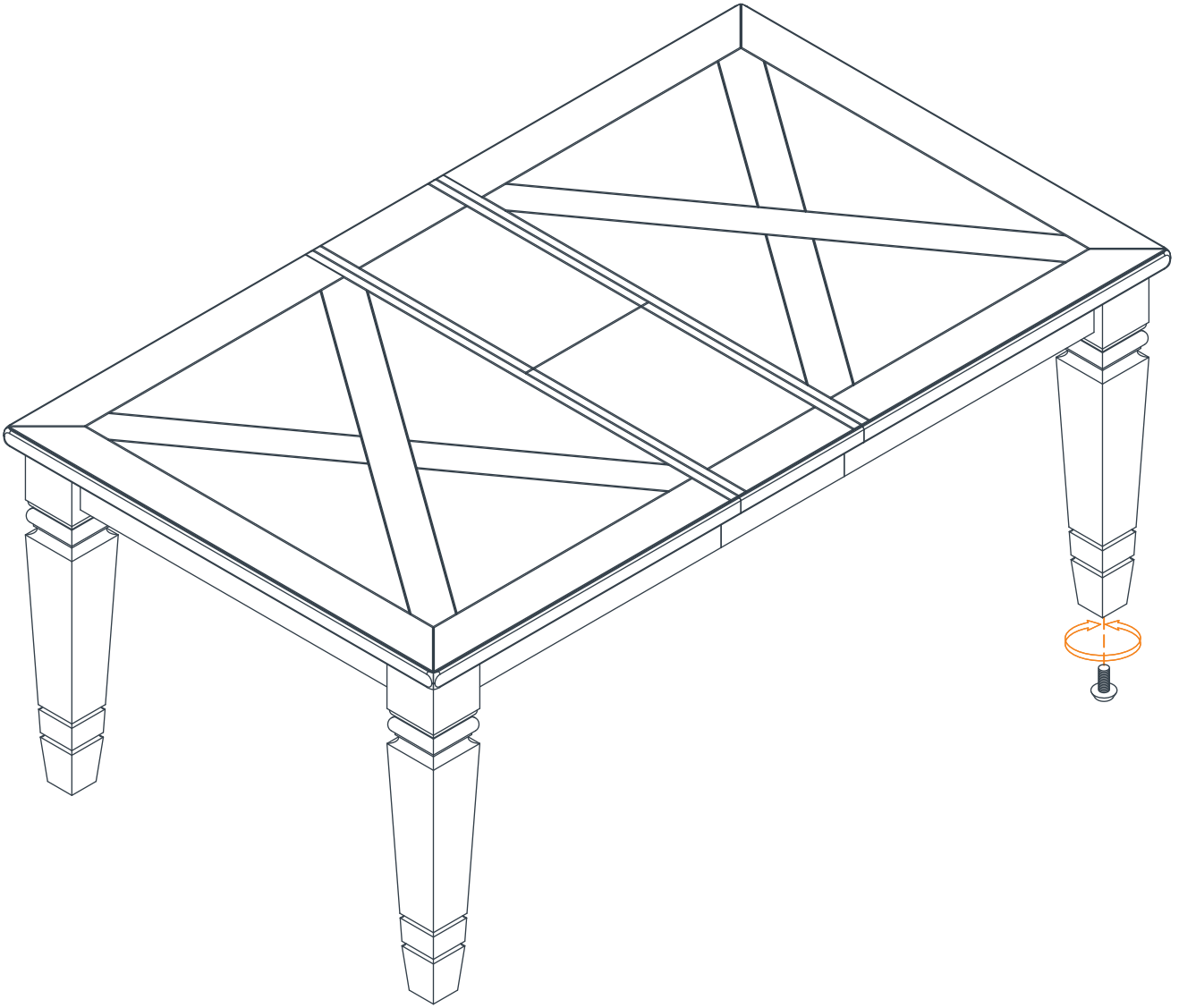

Leveler adjustment
Ajustement des patins réglables
Ajuste de los niveladores

Care & Cleaning:

- Manufacturer recommends not to use furniture polishes or any other chemicals
- Furniture is for indoor use only; temperature and humidity should be regulated
- Use only soft, damp cloth for cleaning
- Avoid direct sunlight as it can cause fading

Entretien et nettoyage :

- Le fabricant recommande de ne pas utiliser de produit à polir ni d'autres produits chimiques.
- Ce meuble est conçu pour un usage intérieur seulement, où la température et le taux d'humidité sont contrôlés.
- Nettoyer uniquement avec un linge doux et humide.
- Éviter l'exposition directe à la lumière du soleil pour prévenir la décoloration.

Cuidado y limpieza:

- El fabricante recomienda no usar ceras para lustrar muebles o cualquier otro químico.
- Este mueble es para uso en interiores solamente. Se debe regular la temperatura y humedad.
- Utilice sólo un paño suave y húmedo para limpiar.
- Evite la luz directa del sol ya que puede causar decoloración.

Distributed by:
Costco Wholesale Corporation
P.O. Box 34535
Seattle, WA 98124-1535
USA
1-800-774-2678
www.costco.com

Costco Wholesale Canada Ltd.*
415 W. Hunt Club Road
Ottawa, Ontario
K2E 1C5, Canada
1-800-463-3783
www.costco.ca
* faisant affaire au Québec sous
le nom les Entrepôts Costco

Importado por:
Importadora Primex S.A. de C.V.
Blvd. Magnocentro No. 4
San Fernando La Herradura
Huixquilucan, Estado de México
C.P. 52765
RFC: IPR-930907-S70
(55)-5246-5500
www.costco.com.mx

Costco Wholesale Australia Pty Ltd
17-21 Parramatta Road
Lidcombe NSW 2141
Australia
www.costco.com.au

Costco Wholesale UK Ltd /
Costco Online UK Ltd
Hartspring Lane
Watford, Herts
WD25 8JS
United Kingdom
01923 213113
www.costco.co.uk

Costco Wholesale Spain S.L.U.
Polígono Empresarial Los Gavilanes
C/ Agustín de Betancourt, 17
28906 Getafe (Madrid) España
NIF: B86509460
900 111 155
www.costco.es

Costco Wholesale Iceland ehf.
Kauptún 3-7, 210 Gardabaer
Iceland
www.costco.is

Costco France
1 avenue de Bréhat
91140 Villebon-sur-Yvette
France
01 80 45 01 10
www.costco.fr

Costco Wholesale Japan Ltd.
3-1-4 Ikegami-Shincho
Kawasaki-ku, Kawasaki-shi,
Kanagawa 210-0832 Japan
0570-032600
www.costco.co.jp

Costco Wholesale Korea, Ltd.
40, Iljik-ro
Gwangmyeong-si
Gyeonggi-do, 14347, Korea
1899-9900
www.costco.co.kr

Costco Wholesale New Zealand Limited
67 Maki Street
Massey, Auckland 0814
New Zealand

Shanghai Minhang Costco Trading Co., Ltd
No. 235, ZhuJian Road
Minhang District, Shanghai
China 201106
+86-21-6257-7065