

ITM. / ART. 1441854

MFR# 8B202QP-1

Queen Storage Bed

Grand Lit avec Rangement

Cama King con Espacio de Almacenamiento



Assembly Instructions

Instructions d'assemblage

Instrucciones de ensamble

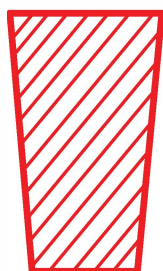

IMPORTANT, RETAIN FOR FUTURE REFERENCE: READ CAREFULLY

For more information, visit: **www.northridge-home.com**

IMPORTANT, À CONSERVER POUR DE FUTURS BESOINS DE RÉFÉRENCE : À LIRE SOIGNEUSEMENT

Pour en savoir plus, visiter le **www.northridge-home.com**



IMPORTANTE: CONSERVE PARA FUTURA REFERENCIA. LEA CUIDADOSAMENTE

Para más información, visite: **www.northridge-home.com**

For parts or customer service call: **1-866-387-8065**

Or email: **info@northridge-home.com**

(English, French and Spanish languages spoken)

Monday-Friday 8am - 8pm (EST).

Telephone number is only valid in the United States and Canada.

Pièces et service à la clientèle : **1-866-387-8065**

Courriel : **info@northridge-home.com**

(Anglais, français et espagnol)

Du lundi au vendredi : de 8 h à 20 h (HNE).

Ce numéro de téléphone n'est valide qu'aux États-Unis et au Canada.

Para solicitar piezas o hablar con un representante

de atención al cliente, llame al **1-866-387-8065**

Correo electrónico: **info@northridge-home.com**

(Atención en español, inglés y francés)

De lunes a viernes, de 8am - 8pm., hora del este.











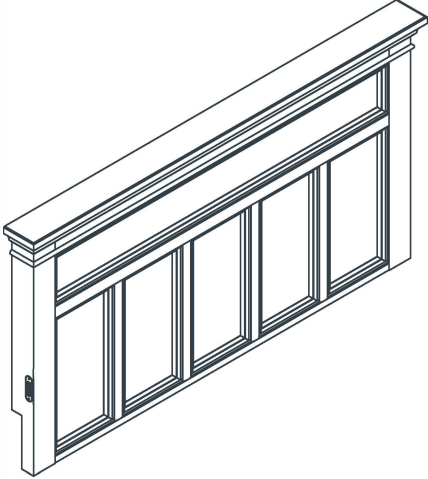

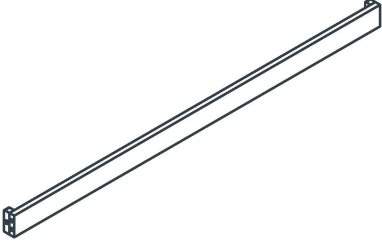
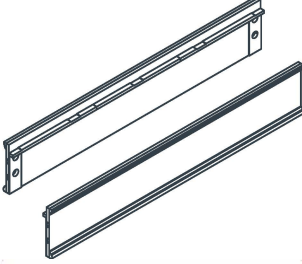
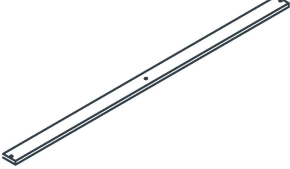

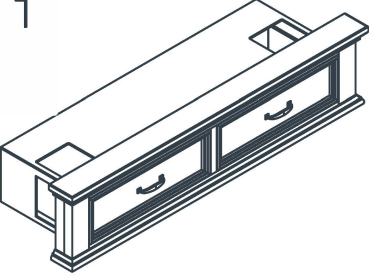
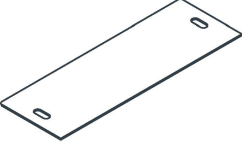



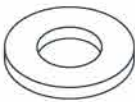

El número es válido solamente en los Estados Unidos y Canadá.

Telefono no válido en Mexico.

WARNING: Small parts choking hazard

AVERTISSEMENT : Risque d'étouffement – Comprend de petites pièces

ADVERTENCIA: Piezas pequeñas. Riesgo de asfixia.

A x 1 		B x 1* 		C x 1* 	
D x 1* 		E x 2* 		F x 4* 	
G x 4* 		H x 1 		I x 4* 	
J x 3* 		K x 2* 		L x 2* 	
M x 6* 		N x 2* 		O x 10* 	
P x 18* 		Q x 1* 		R x 8* 	
S x 8* 		T x 8* 		U x 16* 	
V x 1* 		W x 8* 		Touch-up Pen Crayon de retouche Pluma para retoques 	

1

Note: Assemble bed in desired location.
It is not recommended to move the bed when fully assembled.

N.B. : Monter le lit à l'endroit désiré.
Il est déconseillé de déplacer le lit une fois le montage terminé.

Nota: Monte la cama en el lugar deseado.
No se recomienda moverla después de montarla.

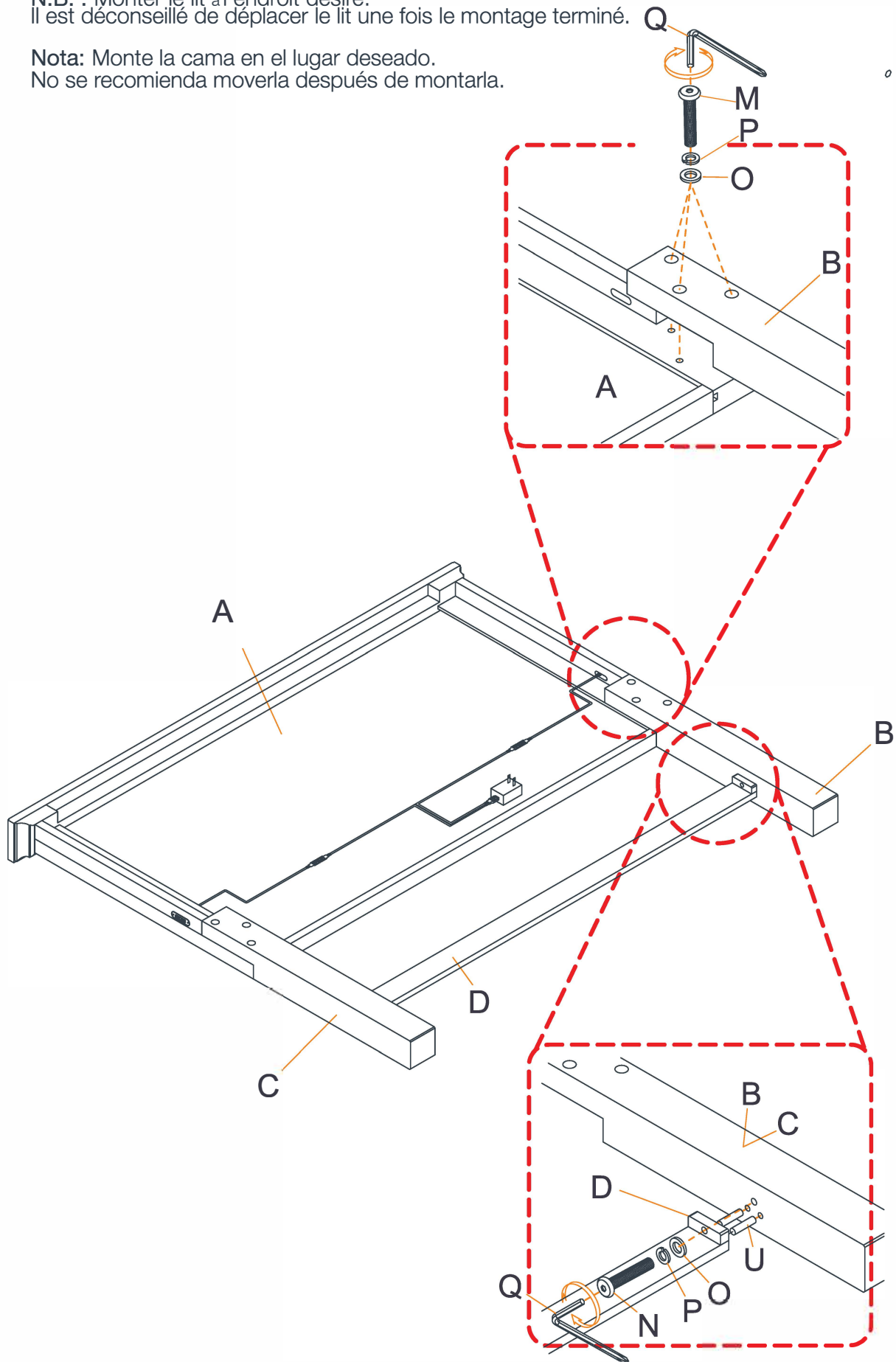

2

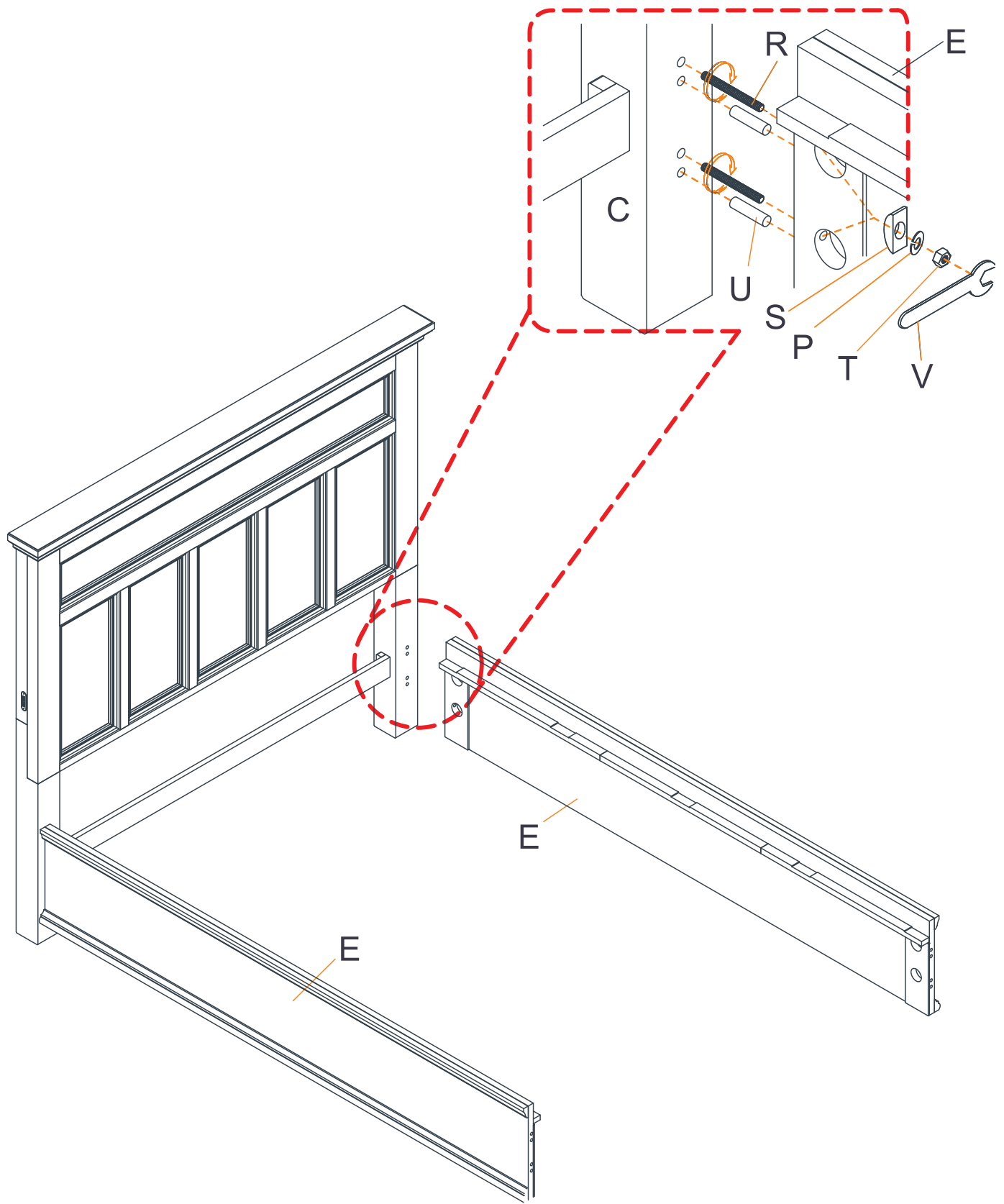

3

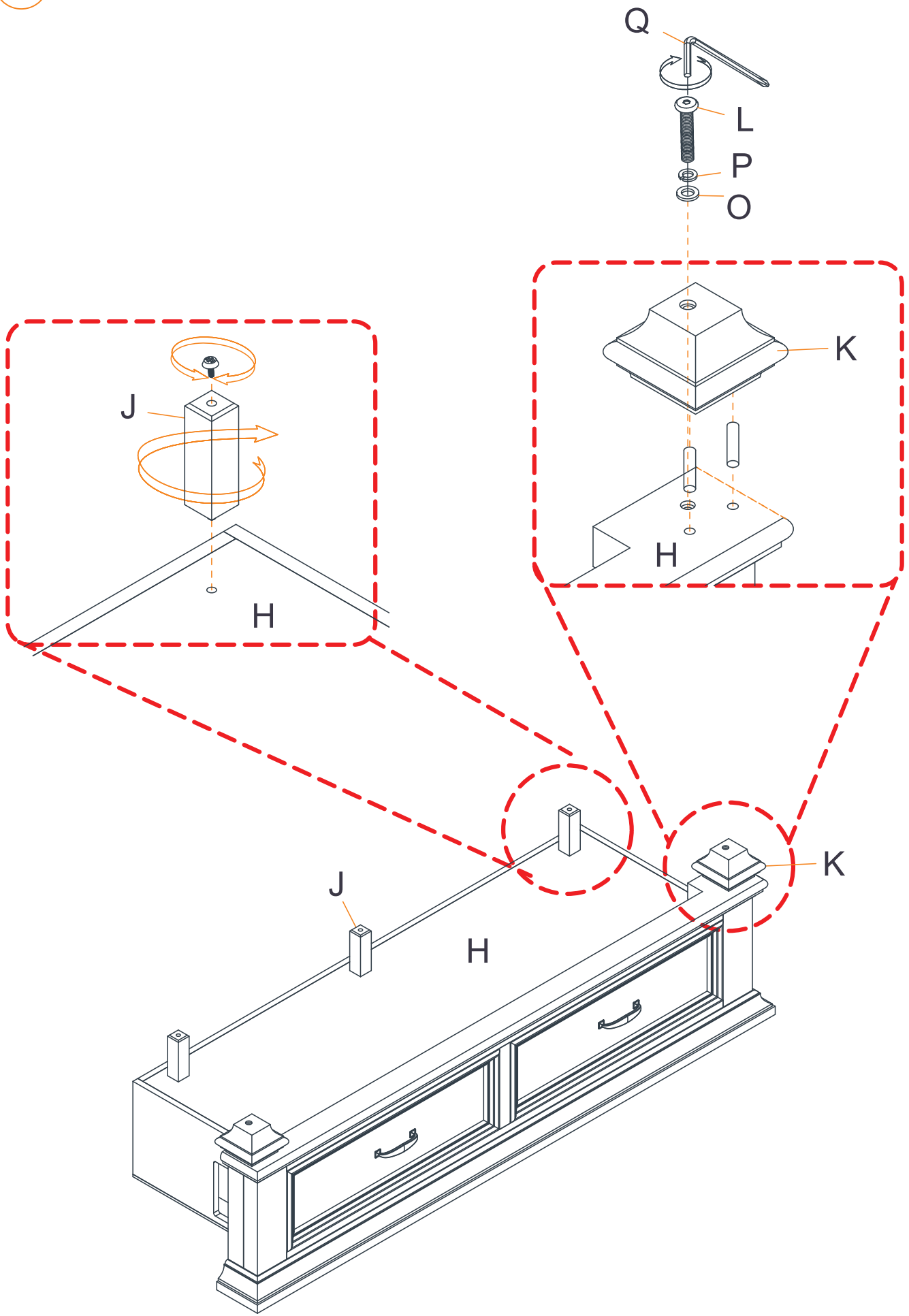

4

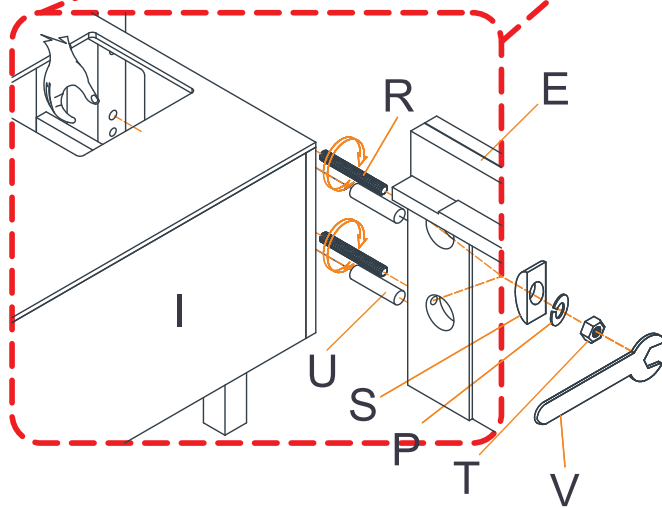
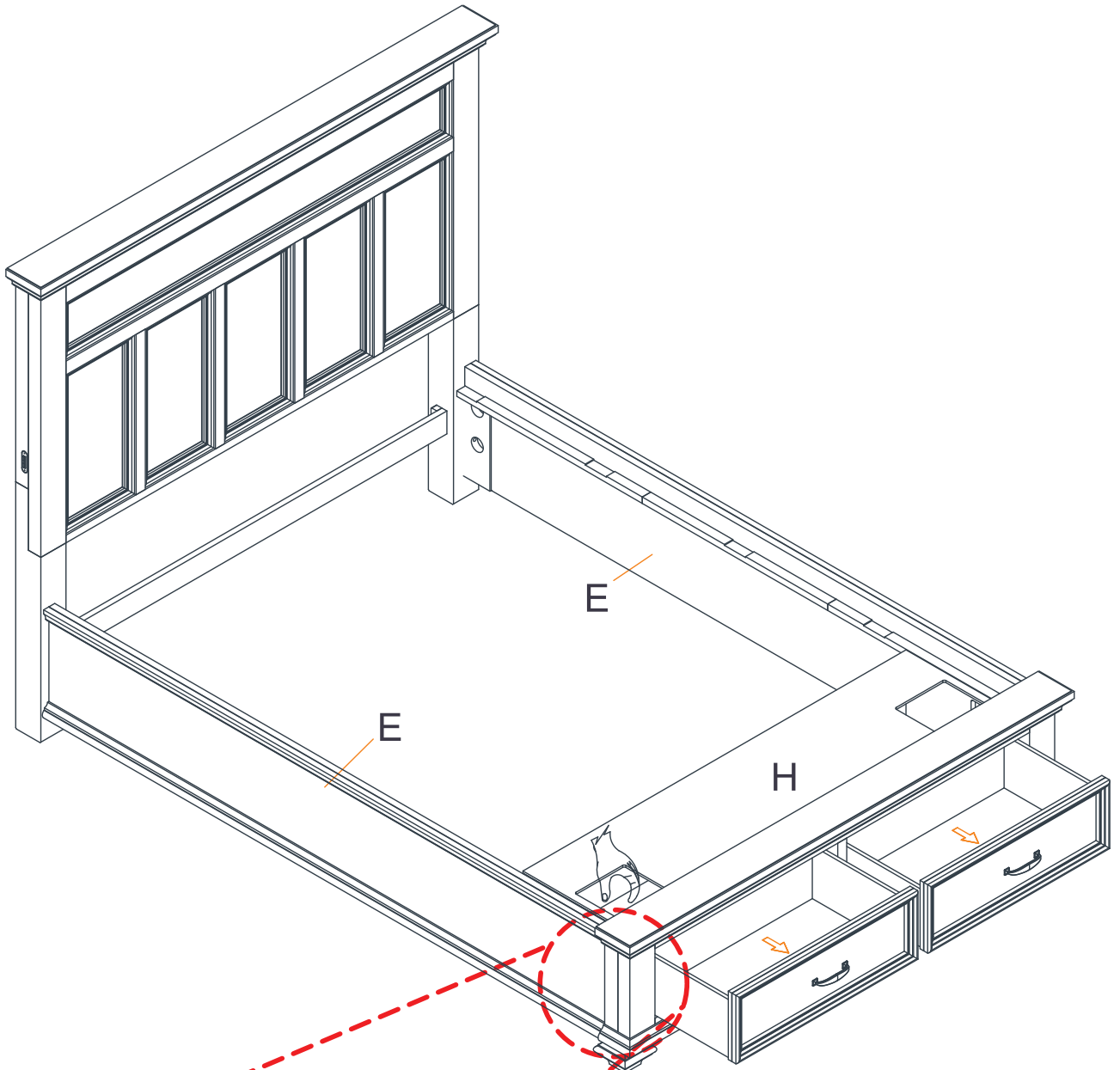

6

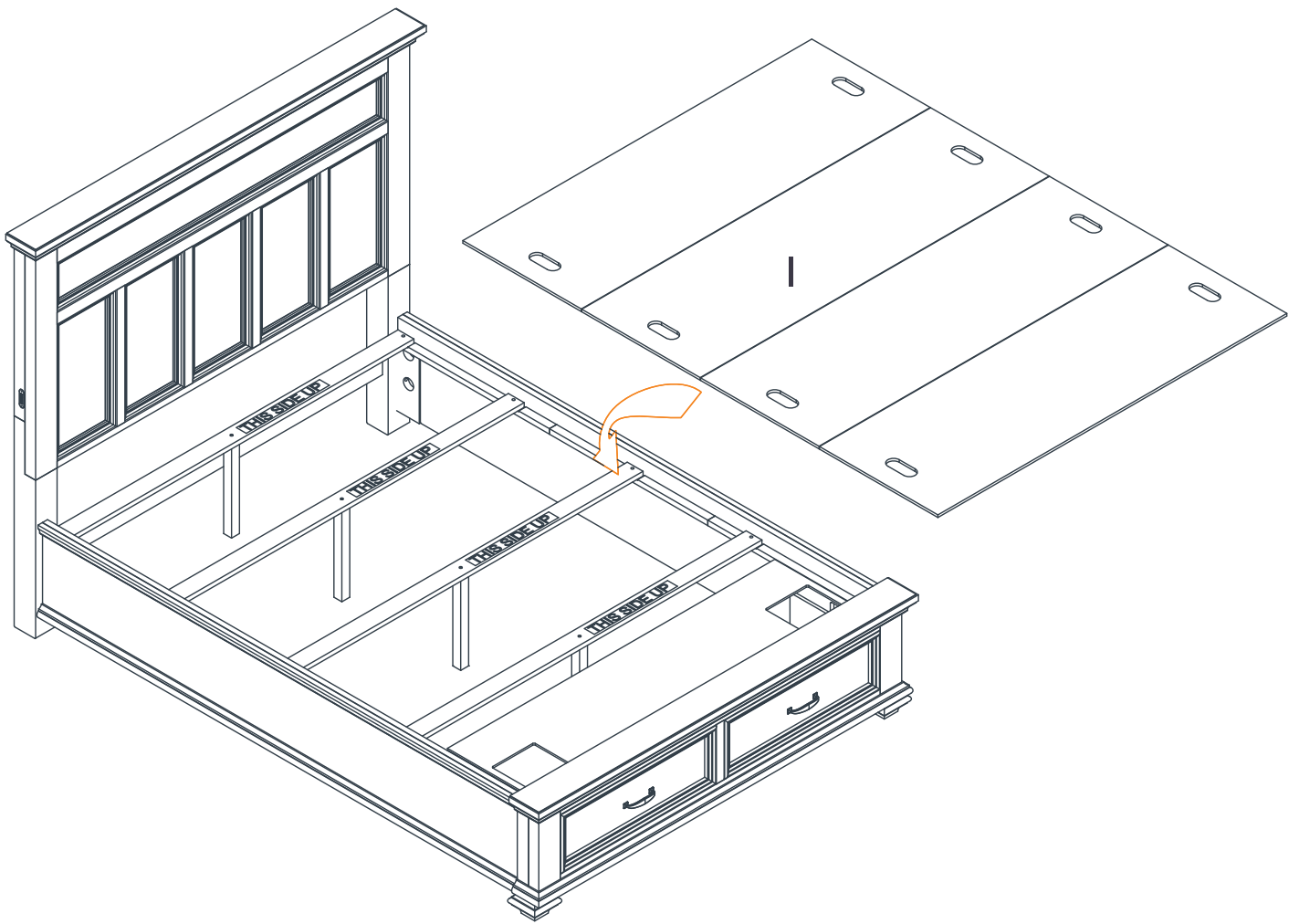

To install drawer:
Installation d'un tiroir :
Para instalar el cajón:

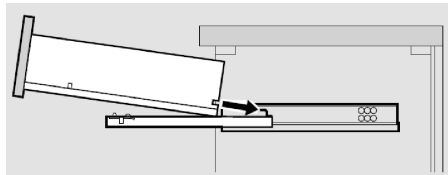
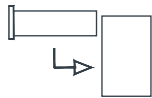

Place the drawer on the runner.
Placer le tiroir sur la glissière.
Coloque el cajón sobre la corredera.

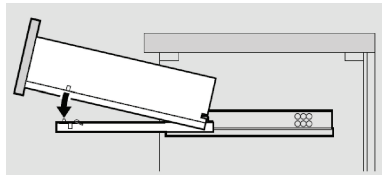

Pull forward until the peg engages with the fixing holes in the drawer base.

Tirer vers soi jusqu'à ce que la cheville s'engage dans les trous de fixation à la base du tiroir.

Tírelo hacia delante hasta que la estaca se engrana con los agujeros de fijación en la base del cajón.

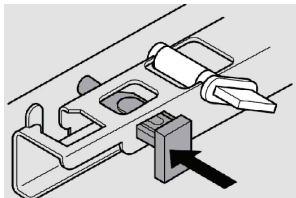
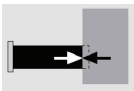

Lock the peg by pushing inside the hole in the drawer base side.

Bloquer la cheville en la poussant dans le trou, sur le côté de la base du tiroir.

Bloquee la estaca presionando dentro del agujero en el lado de la base del cajón.

To remove drawer:

Retrait d'un tiroir :

Para retirar el cajón:

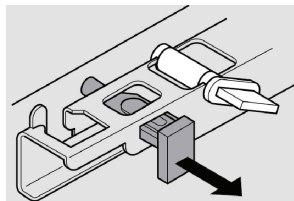

Open the lock by pushing the peg out of the hole.

Débloquer le verrou en poussant la cheville hors du trou.

Abra el bloqueo presionando la estaca fuera del agujero.

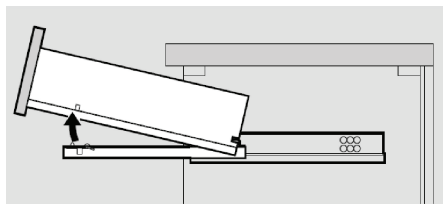

Pull the peg out of the fixing holes in the drawer base.

Tirer la cheville hors des trous de fixation à la base du tiroir.

Retire la estaca de los agujeros de fijación en la base del cajón.

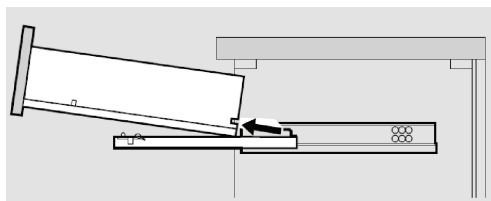

Pull all of the drawers out of the case.

Sortir tous les tiroirs du meuble.

Retire todos los cajones de la caja.

Toolless height adjustment:

Ajustement de la hauteur sans outil :

Ajuste de altura sin necesidad de herramientas:

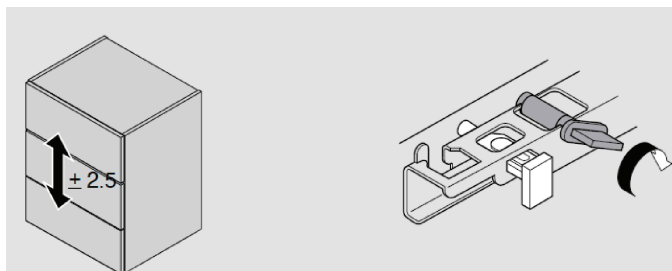

Turn the lock next to the peg from left to right.

Tourner le verrou situé à côté de la cheville de gauche à droite.

Gire el bloqueo junto a la estaca de izquierda a derecha.

 **blum**®

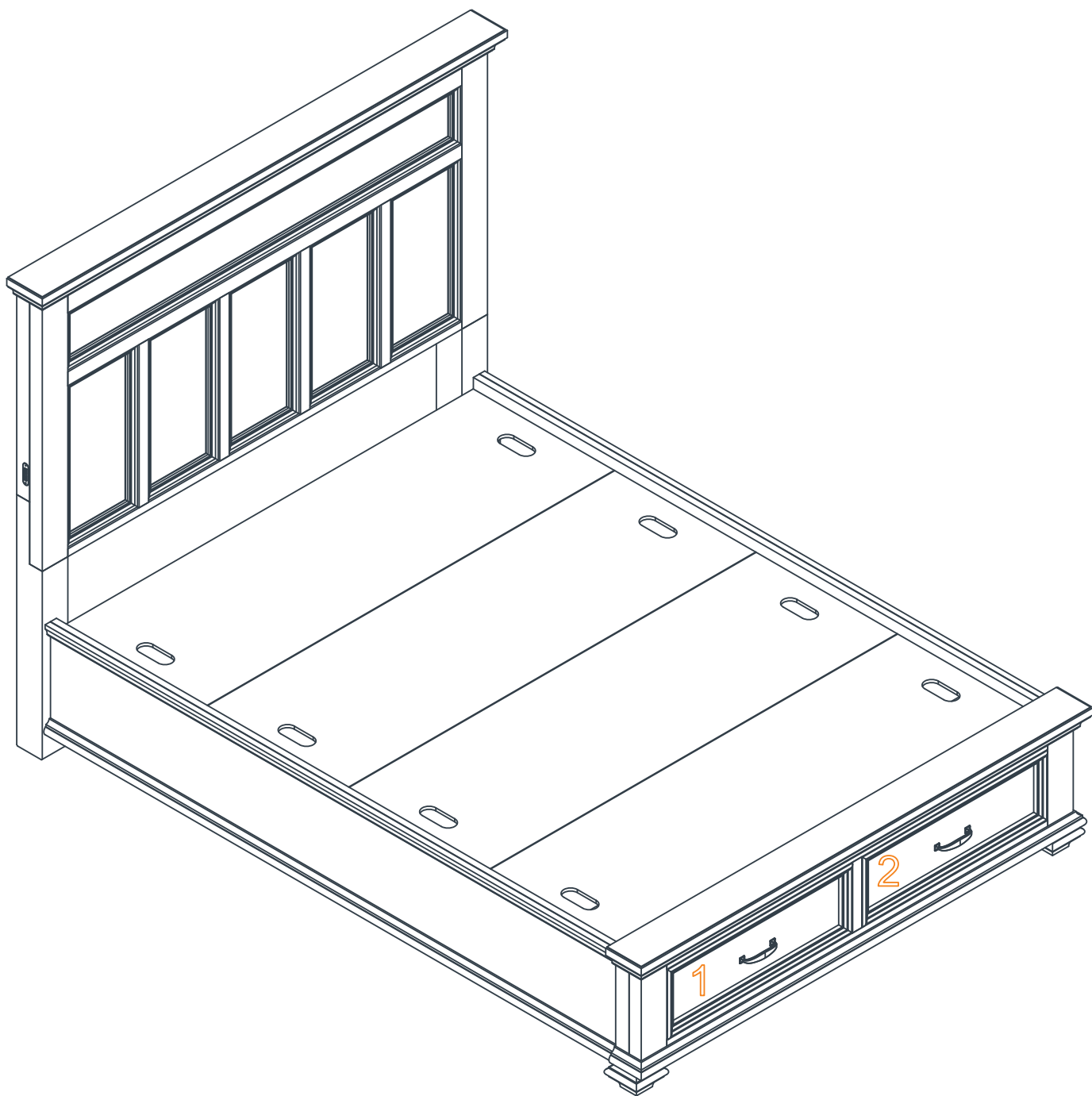

In case drawers need to be removed, each drawer is individually numbered underneath the drawer box with the corresponding number on top of the dust partition, inside the case.

S'il faut retirer les tiroirs, remarquer que chaque tiroir est numéroté. Faire correspondre le numéro situé sous le tiroir à celui sur la séparation antipoussière à l'intérieur de la commode.

En caso que sea necesario sacar los cajones, cada uno tiene un número individual. El número está escrito en el cajón y en el separador antipolvo que le corresponde dentro de la cómoda.

Care & Cleaning:

- Manufacturer recommends not to use furniture polishes or any other chemicals.
- Furniture is for indoor use only; temperature and humidity should be regulated.
- Use only soft, damp cloth for cleaning.
- Avoid direct sunlight as it can cause fading.

Entretien et nettoyage

- Le fabricant recommande de ne pas utiliser de produit à polir ni d'autres produits chimiques.
- Ce meuble est conçu pour un usage intérieur seulement, où la température et le taux d'humidité sont contrôlés.
- Nettoyer uniquement avec un linge doux et humide.
- Éviter l'exposition directe à la lumière du soleil pour prévenir la décoloration.

Cuidado y limpieza:

- El fabricante recomienda no usar ceras para lustrar muebles o cualquier otro químico.
- Este mueble es para uso en interiores solamente. Se debe regular la temperatura y humedad.
- Utilice sólo un paño suave y húmedo para limpiar.
- Evite la luz directa del sol ya que puede causar decoloración.

Distributed by:
Costco Wholesale Corporation
P.O. Box 34535
Seattle, WA 98124-1535
USA
1-800-774-2678
www.costco.com

Costco Wholesale Canada Ltd.*
415 W. Hunt Club Road
Ottawa, Ontario
K2E 1C5, Canada
1-800-463-3783
www.costco.ca

*faisant affaire au Québec sous
le nom les Entrepôts Costco

Importadora Primex S.A. de C.V.
Blvd. Magnocentro No. 4
San Fernando La Herradura
Huixquilucan, Estado de México
C.P. 52765
RFC: IPR-930907-S70
(55)-5246-5500
www.costco.com.mx